



MasterMatic

NO 4 COLRADO COURT, HALLAM, VIC. 3803

Phone: (03) 9796 3611 A.H: (03) 9883 7526
Mobile: (018) 314 173 Fax: (03) 9796 3823
A.C.N. 006 340 969

ADS SPIN 4

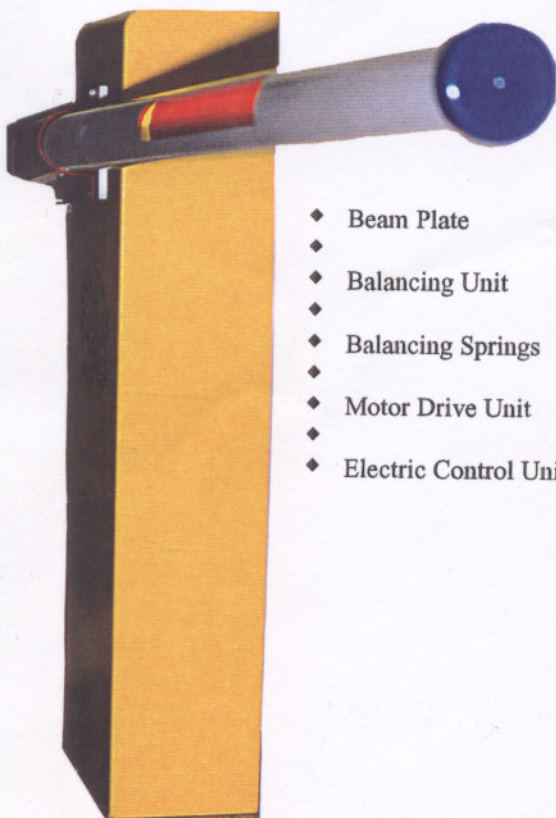

- ◆ Beam Plate
- ◆ Balancing Unit
- ◆ Balancing Springs
- ◆ Motor Drive Unit
- ◆ Electric Control Unit

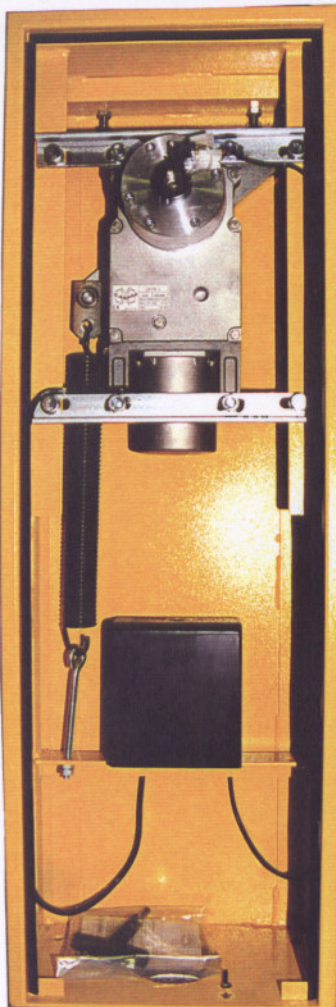

*1 - The helical, compression springs, easy to adjust, guarantee a smooth movement of the beam both at opening and closing.

*2 - In case of power blackout, the emergency release is provided by turning a knob on the motor unit: it allows the manual operation of the beam and its stopping at the desired position.

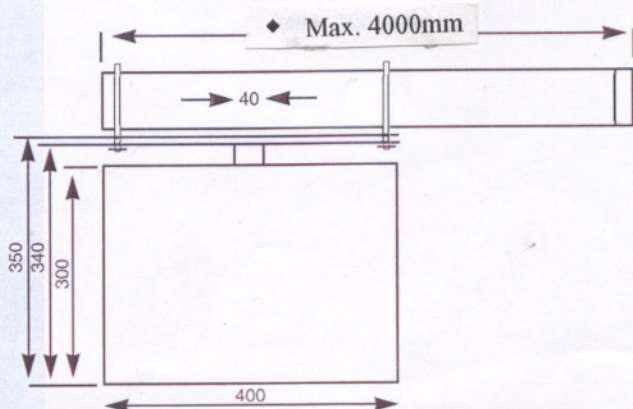

ADS Spin4

Universal Barrier

This automatic boom gate barrier consists of an aluminium beam, powdercoated white, and equipped with red reflector tape, a steel casing with cathaphoresis treatment and painted with polyester powder coating on the housing and containing an electromechanical, non-reversible motor and electronic logic control. The unit is equipped with anti-crash safety devices and manual release in the event of a power failure or faulty operation.

Technical Data.

Max. Barrier Arm Length	4000mm
Max. Opening Time[secs.]	4
Angle Speed [r.p.m.]	2
Max. Torque [Nm]	100
Types of Barriers	Rigid or Articulated
Frequency of Operation	75%
Power Supply	240VAC 50HZ
Absorbed Power	400W
Thermal Protection of the winding in degrees	140 C
Operating Temps.	-20 +55 C
Weight	70Kg.
Power of Motor	380W
Speed of Motor	2800RPM.

Optional Extras.

- Fork support for boom arm.
- Electromagnetic plate lock for fork support to lock down boom arm.
- Radio Receiver.
- Radio Transmitter.
- Photo Electric Safety Cells.
- Electronic Loop Detectors.
- Flashing Warning Lamps.

