

H-18

HEAVY DUTY DOOR

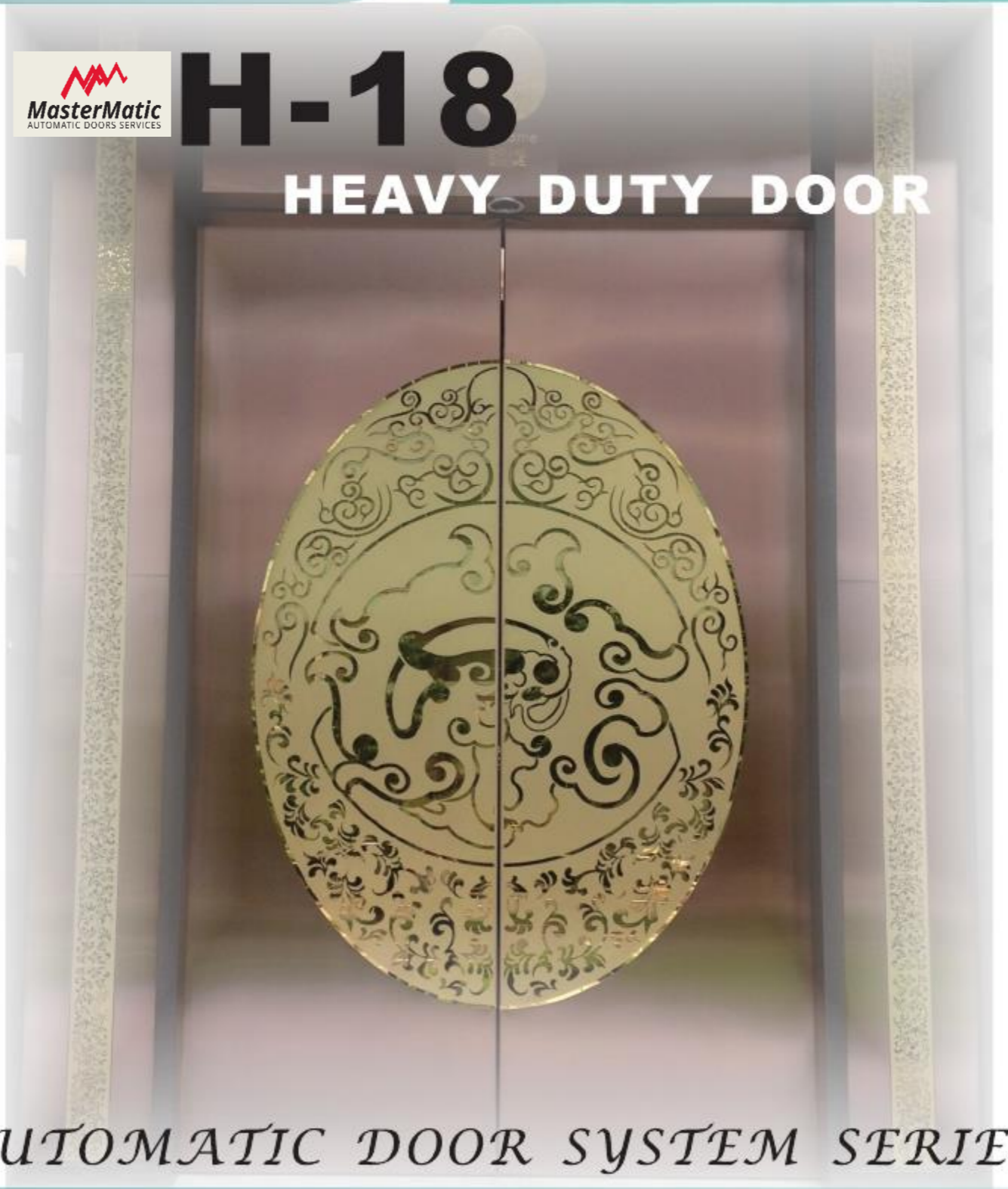

AUTOMATIC DOOR SYSTEM SERIES

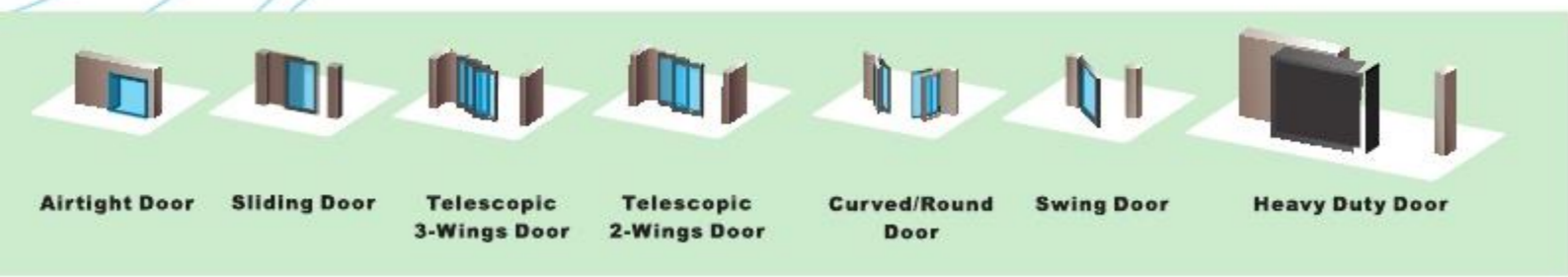

A.D.S MasterMatic PTY LTD

4 Colorado ct
 Hallam, VICTORIA 3803
www.adsmastermatic.com.au
info@adsmastermatic.com.au
 P: (03) 9796 3611
 F: (03) 9796 3823



H-18 HEAVY DUTY DOOR



DURABLE HANGERS



ROLLER CHAIN



H-18 CONTROLLER WITH CTB DEVICE



DC24V 180W MOTOR WITH PLANETARY GEAR



- Install in factories, airports, military bases and other high security areas to be protected.
- Special tracks and wheels, carrying heavier and more stable.
- Using a large radius of the pulley and greatly reduce noise and enhance the useful time.
- DC24V 180W Brushless DC Motor. (Planetary Gear)

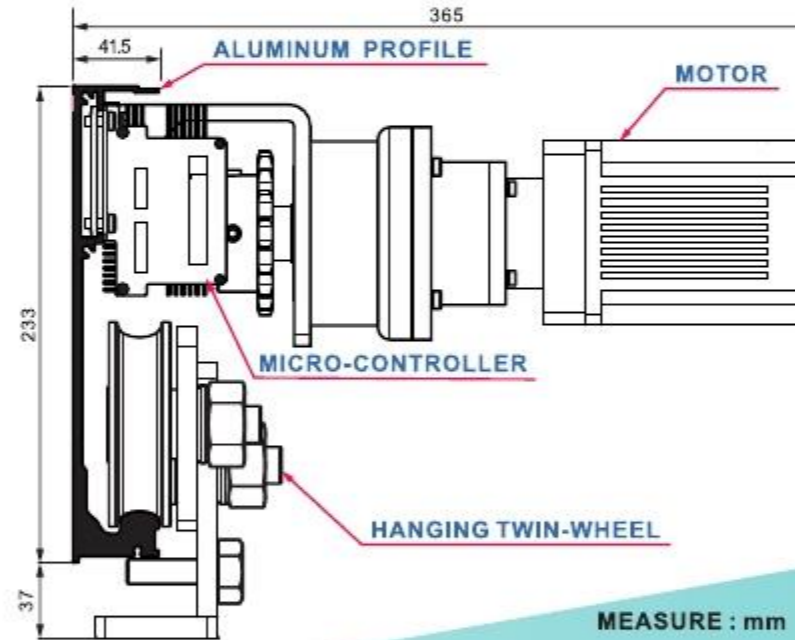

MEASURE : mm

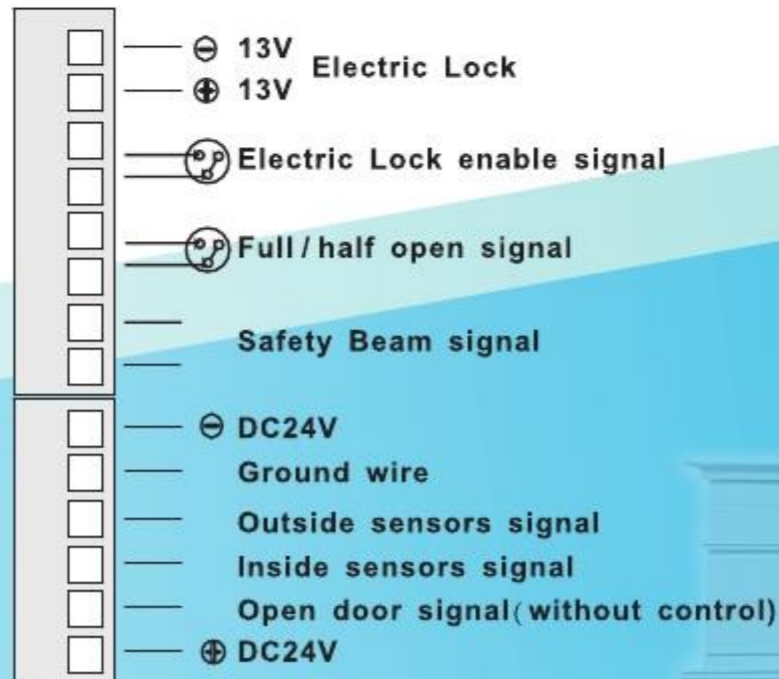

TYPE	H-18	
MODEL	SINGLE-WINGED	BI-PARTING
DOOR WEIGHT	1000kg X1 (DOOR)	900kg X2 (DOOR)
DOOR WIDTH	500mm~6000mm	500mm~6000mm
INSTALL WAY	SURFACE INSTALL	SURFACE INSTALL
MOTOR	DC24V 180W BRUSHLESS DC MOTOR (PLANETARY GEAR)	
CONTROL	STANDARD MICRO-CONTROL	
POWER CONSUMPTION	180W	
VOLTAGE	AC100V~240V	
ENVIRONMENTAL TEMPERATURE	-20°C~+50°C	
VOLUME	65 DECIBEL(MAX.)	
STARTING SPEED	300mm/SEC.	250mm/SEC.
STARTING TIMES	0~20 SEC. (REGULABLE)	
TRANSMISSION IMPORTANT CONDITION	ROLLER CHAIN 40-1R	
OPENING DOOR RANGE	FULL/HALF-OPEN (REGULABLE)	
PFC POWER EFFICIENCY	0.95(IN AC100V FULL LOAD)	
TRACTION FORCE	WHEN POWER OFF THE DOOR CAN BE OPENED BY MANUAL	